

* SPECIFICATION

Mx. PRESSURE RATING : 2Mpa

Mx. TEMPERATURE RATING : 100°C

TYPE	P	d	D	H	L	W	G	11	STOP NUT	B S B M	1	
VFF-101	Rc 1/8	3	17	58.5	46	35	14.5	10	STEM	SUS 316	1	
VFF-202	Rc 1/4	3	17	58.5	49	35	14.5	9	NUT	SUS 316	1	
注文先	殿							7	SET SCREW	SCM 435	1	
品名	VFF							6	STOP RING	RUBBER	1	
部品番号		数量						5	WASHER	SUS 304	1	
材質		尺度	N/S					4	BACK-UP RING	P T F E	1	
作 図 年 月 日		図 番						3	"O"RING	VITON	1	
主任		係		製 図		設 計		2	PANEL NUT	SUS 316	1	
								1	B O D Y	SUS 316	1	
								PART NO	NAME OF PART	M A T E R I A L	QNTY	R E M A R K

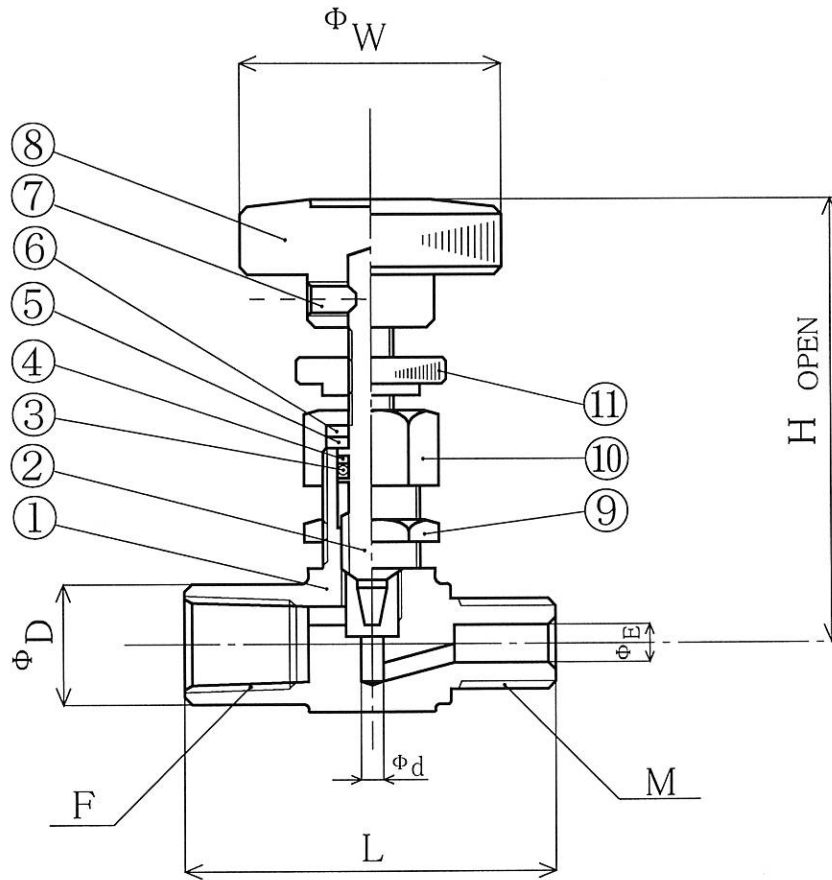

* SPECIFICATION

Mx. PRESSURE RATING : 2Mpa

Mx. TEMPERATURE RATING : 100°C

									11	STOP NUT	BSBM	1					
VMF-101	Rc 1/8	R 1/8	17	5	3	47	58.5	35	10	NUT	SUS 304	1					
VMF-202	Rc 1/4	R 1/4	17	6	3	49	58.5	35	9	PANEL NUT	SUS 304	1					
T Y P E	F	M	D	E	d	L	H	W	8	HAND WHEEL	NYLON	1					
注文先	殿								7	SET SCREW	SCM 435	1					
品名	VMF								6	STOP RING	RUBBER	1					
部品番号			数量										5	WASHER	SUS 304	1	
材質			尺度		N/S								4	BACK-UP RING	P T F E	1	
作図年月日			図番										3	"O"RING	VITON	1	
主任			係		製図		設計			2	STEM	SUS 316	1				
										1	BODY	SUS 316	1				
										PART NO	NAME OF PART	M A T E R I A L	QNTY	REMARK			

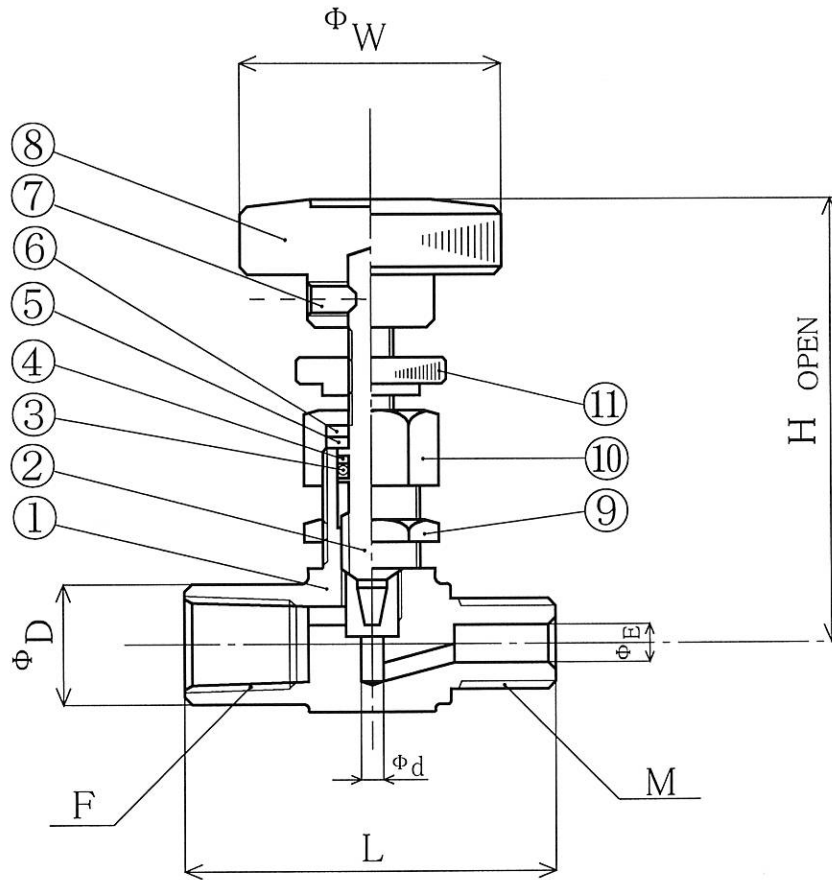

* SPECIFICATION

Mx. PRESSURE RATING : 2Mpa

Mx. TEMPERATURE RATING : 100°C

									11	STOP NUT	BSBM	1					
VMF-101	Rc 1/8	R 1/8	17	5	3	47	58.5	35	10	NUT	SUS 304	1					
VMF-202	Rc 1/4	R 1/4	17	6	3	49	58.5	35	9	PANEL NUT	SUS 304	1					
T Y P E	F	M	D	E	d	L	H	W	8	HAND WHEEL	NYLON	1					
注文先	殿								7	SET SCREW	SCM 435	1					
品名	VMF								6	STOP RING	RUBBER	1					
部品番号			数量										5	WASHER	SUS 304	1	
材質			尺度		N/S								4	BACK-UP RING	P T F E	1	
作図年月日			図番										3	"O"RING	VITON	1	
主任			係		製図		設計			2	STEM	SUS 316	1				
										1	BODY	SUS 316	1				
										PART NO	NAME OF PART	M A T E R I A L	QNTY	REMARK			

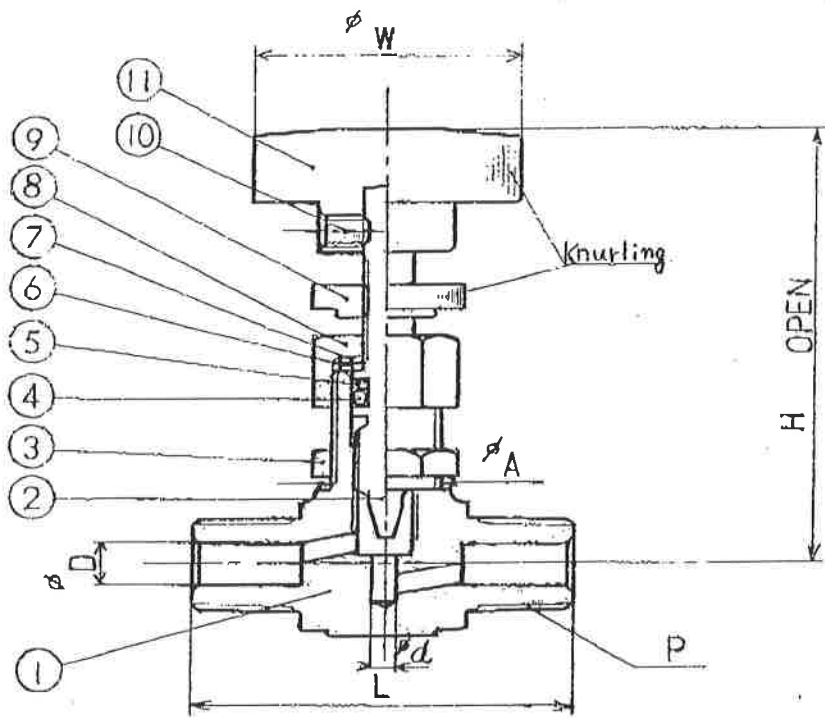

								11	HAND WHEEL	NYLON	1	
VMM-101	R 1/8	5	3	44	58.5	35	145	10	SET SCREW	SMC 435	1	
TYPE	P	D	d	L	H	W	A	9	STOP NUT	BSBM	1	
								8	NUT	SUS 304	1	
注文先								7	STOP RING	RUBBER	1	
品名	VMM							6	WASHER	SUS 304	1	
部品番号			数量									
材質			尺度	N/S								
作図年月日			図番									
主任		係	製図	S.J. to				設計				
								1	BODY	SUS 316	1	
								PART NO	NAME OF PART	MATERIAL	QNTY	REMARK

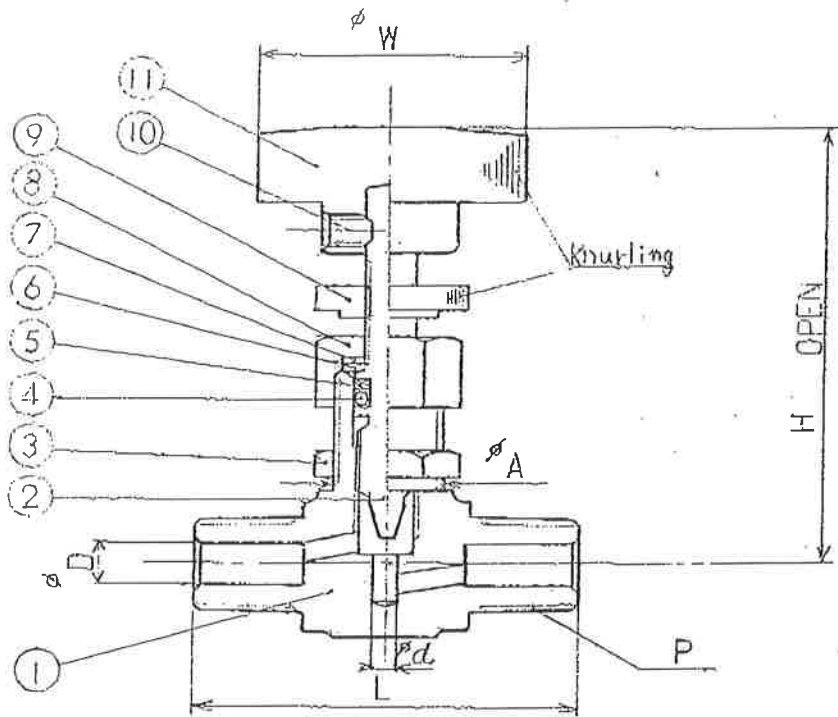

								11	HAND WHEEL	NYLON	1		
VMM-202	R 1/4	6	3	49	58.5	35	145	10	SET SCREW	SMC 435	1		
TYPE	P	D	d	L	H	W	A	9	STOP NUT	BSBM	1		
								8	NUT	SUS 304	1		
注文先								殿	7	STOP RING	RUBBER	1	
品名	VMM								6	WASHER	SUS 304	1	
部品番号				数量				5	BACKUP RING	PTFE	1		
材質				尺度	N/S			4	"O" RING	VITON	1		
作図年月				図番				3	PANEL NUT	SUS 304	1		
								2	STEM	SUS 316	1		
主任		係		製図	S.Y. 志	設計		1	BODY	SUS 316	1		
								PART NO	NAME OF PART	MATERIAL	QNTY	REMARK	

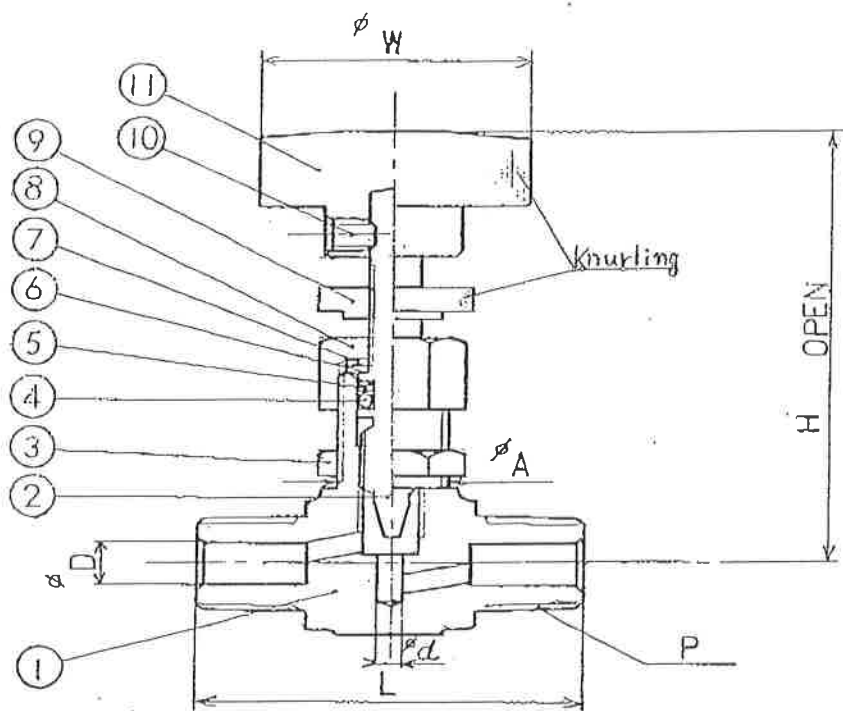

VMM-303	R 3/8	8	3	51	58.5	35	145	11	HAND WHEEL	NYLON	1	
TYPE	P	D	d	L	H	W	A	10	SET SCREW	SMC 435	1	
								9	STOP NUT	BSBM	1	
								8	NUT	SUS 304	1	
注文先								7	STOP RING	RUBBER	1	
品名	VMM							6	WASHER	SUS 304	1	
部品番号			数量					5	BACKUP RING	PTFE	1	
材質			尺度	N/S				4	"O" RING	VITON	1	
作図年月日			図番					3	PANEL NUT	SUS 304	1	
主任		係	製図	S.Jto	設計			2	STEM	SUS 316	1	
								1	BODY	SUS 316	1	
								PART NO	NAME OF PART	MATERIAL	QNTY	REMARK

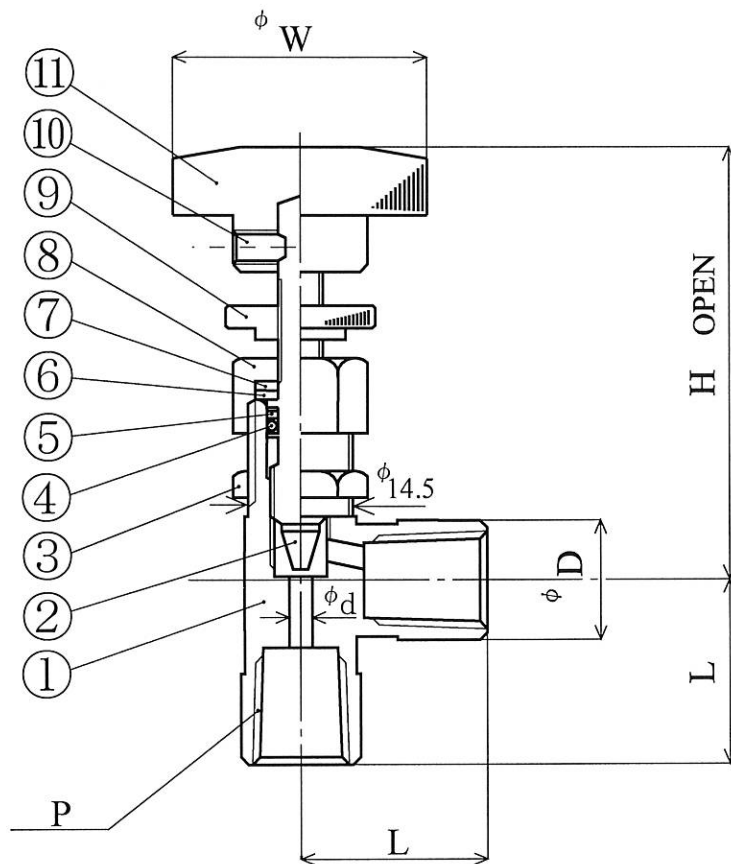

							11	HAND WHEEL	NYLON	1	
VFL-101	Rc 1/8	23	58.5	35	3	17	10	SET SCREW	SCM 435	1	
VFL-202	Rc 1/4	25	58.5	35	3	17	9	STOP NUT	BSBM	1	
TYPE	P	L	H	W	d	D	8	NUT	SUS 316	1	
注文先	殿						7	STOP RING	RUBBER	1	
品名	VFL						6	WASHER	SUS 304	1	
部品番号		数量					5	BACK-UP RING	PTFE	1	
材質		尺度	N/S				4	"O"RING	VITON	1	
作図 年月日		図番					3	PANEL NUT	SUS 316	1	
主任		係		製図		設計	2	STEM	SUS 316	1	
							1	BODY	SUS 316	1	
							PART NO	NAME OF PART	MATERIAL	QNTY	REMARK

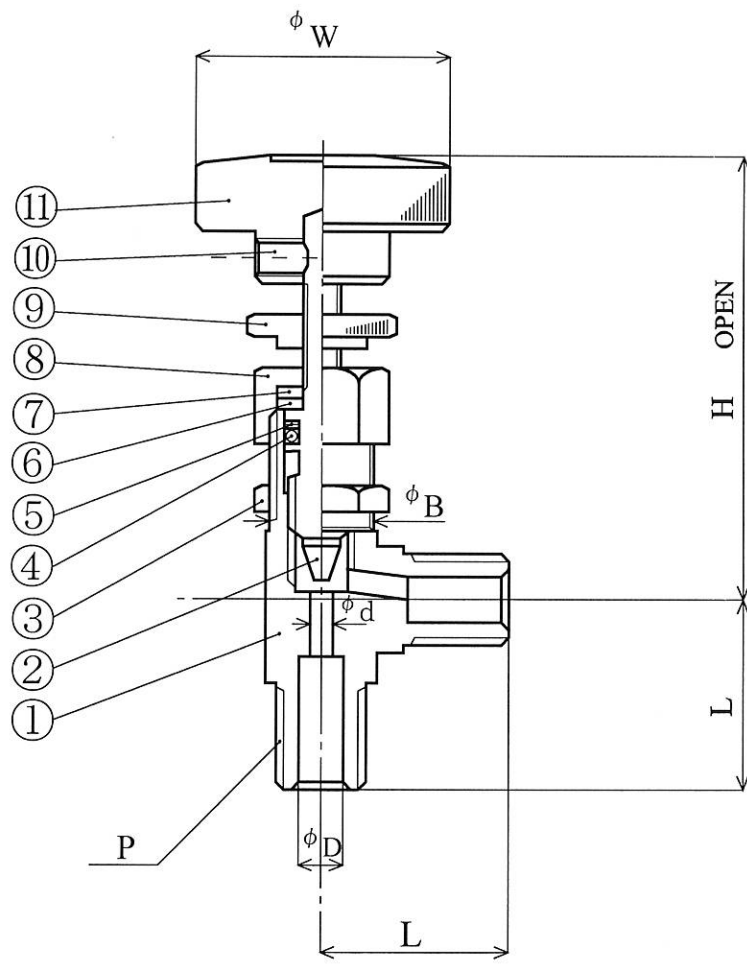

* SPECIFICATION

Mx. PRESSURE RATING : 2Mpa

Mx. TEMPERATURE RATING : 100°C

								11	HANDLE	NYLON	1	
VML-202	R 1/4	6	3	25	58.5	14.5	35	10	SET SCREW	SCM 435	1	
VML-101	R 1/8	5	3	23	58.5	14.5	35	9	STOP NUT	BSBM	1	
TYPE	P	D	d	L	H	B	W	8	NUT	SUS 304	1	
注文先	殿							7	STOP RING	RUBBER	1	
品名	VML							6	WASHER	SUS 304	1	
部品番号			数量					5	BACK-UP RING	P T F E	1	
材質			尺度				N/S	4	"O"RING	VITON	1	
作図年月日			図番					3	PANEL NUT	SUS 316	1	
主任		係		製図		設計		2	STEM	SUS 316	1	
								1	BODY	SUS 316	1	
								PART NO	NAME OF PART	MATERIAL	QNTY	REMARK