

GU1型 B1 UNION

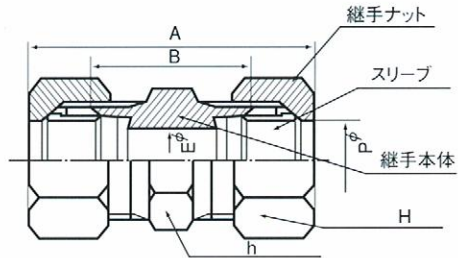

呼称	P	A	B	E	h	H
GU1-4-B1	4	35	20	2.5	8	10
GU1-6-B1	6	38	22	4	10	12
GU1-8-B1	8	39	23	6	12	14
GU1-10-B1	10	42	25	8	14	17
GU1-12-B1	12	46	26	10	17	19
GU1-14-B1	14	46	27	11	21	23
GU1-15-B1	15	46	27	12	21	23
GU1-20-B1	20	50	30	17	26	29
GU1-25-B1	25	54	34	20	20	36

GC型 B1 MALE CONNECTOR

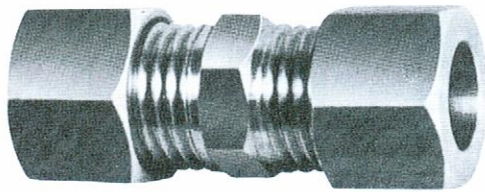
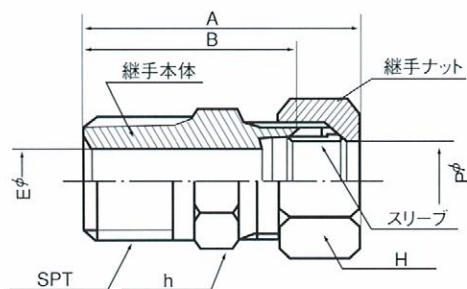
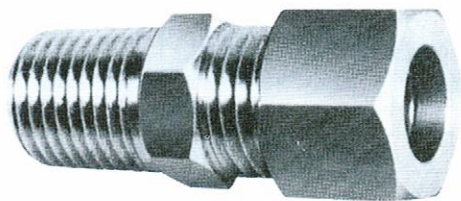

呼称	P	S	A	B	E	h	H
GC-4 × 1/8 B1	4	1/8	31	23	2.5	10	10
GC-6 × 1/8 B1	6	1/8	32	24	4	10	12
GC-6 × 1/4 B1	6	1/4	37	29	4	14	12
GC-6 × 3/8 B1	6	3/8	38	30	4	17	12
GC-6 × 1/2 B1	6	1/2	44.5	37	4	23	12
GC-8 × 1/8 B1	8	1/8	33	25	4	12	14
GC-8 × 1/4 B1	8	1/4	37	29	6	14	14
GC-8 × 3/8 B1	8	3/8	38	30	6	17	14
GC-8 × 1/2 B1	8	1/2	45	37	6	23	14
GC-10 × 1/8 B1	10	1/8	35	26	4	14	17
GC-10 × 1/4 B1	10	1/4	38	30	6	14	17
GC-10 × 3/8 B1	10	3/8	39	31	8	17	17
GC-10 × 1/2 B1	10	1/2	46	37	8	23	17
GC-12 × 1/4 B1	12	1/4	39	31	6	17	19
GC-12 × 3/8 B1	12	3/8	40	32	8.5	17	19
GC-12 × 1/2 B1	12	1/2	46	37	10	23	19
GC-14 × 3/8 B1	14	3/8	43	33	8.5	21	23
GC-14 × 1/2 B1	14	1/2	47	37	11	23	23
GC-15 × 3/8 B1	15	3/8	43	33	8.5	21	23
GC-15 × 1/2 B1	15	1/2	47	37	12	23	23
GC-20 × 1/2 B1	20	1/2	48	39	12	26	29
GC-20 × 3/4 B1	20	3/4	51	42	17	29	29
GC-25 × 3/4 B1	25	3/4	53	43	17	32	36
GC-25 × 1" B1	25	1"	56	46	20	35	36

GT1型 B1 UNION TEE

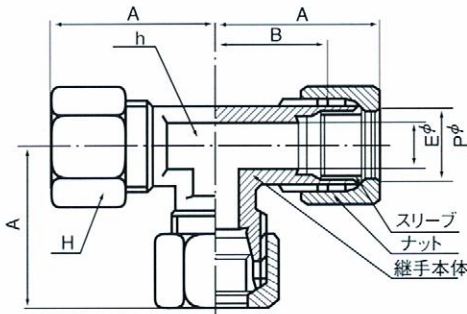
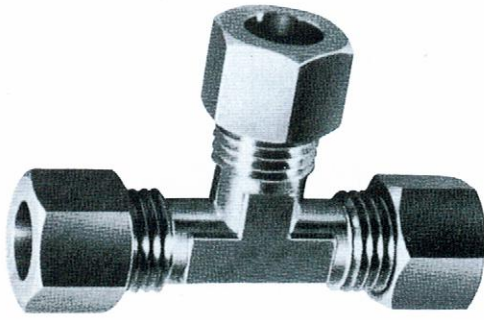

呼称	P	A	B	E	h	H
GT1 - 4-B1	4	23.5	16	25	8	10
GT1 - 6-B1	6	27	19	4	8	12
GT1 - 8-B1	8	27	19	6	10	14
GT1 - 10-B1	10	28.5	21	8	12	17
GT1 - 12-B1	12	32	22	10	14	19
GT1 - 14-B1	14	35	25	11	17	23
GT1 - 15-B1	15	34.5	25	12	17	23
GT1 - 20-B1	20	39	29	17	23	29
GT1 - 25-B1	25	44	35	20	29	36

GL2型 B1 MALE ELBOW

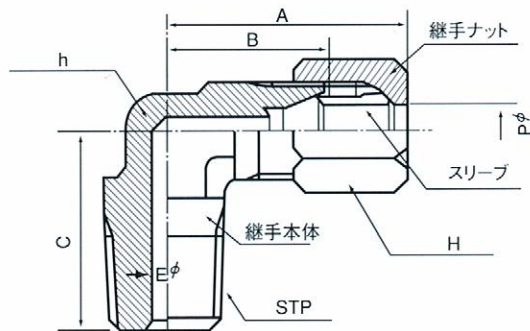
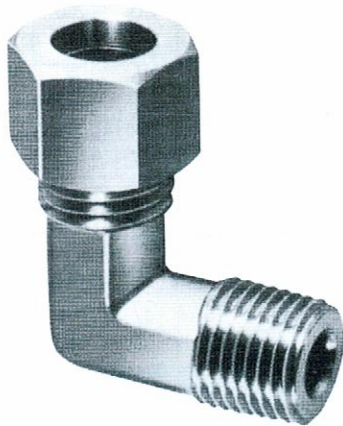

呼称	P	S	A	B	C	E	h	H
GL2 - 4 × 1/8 B1	4	1/8	25	16	17	2.5	8	10
GL2 - 6 × 1/8 B1	6	1/8	27	19	19	4	8	12
GL2 - 6 × 1/4 B1	6	1/4	27	19	22	6	8	12
GL2 - 6 × 3/8 B1	6	3/8	29.5	21	24	8.5	12	12
GL2 - 6 × 1/2 B1	6	1/2	34	24	31	12	17	12
GL2 - 8 × 1/8 B1	8	1/8	27	19	19	4	10	14
GL2 - 8 × 1/4 B1	8	1/4	27	19	22	6	10	14
GL2 - 8 × 3/8 B1	8	3/8	29	21	24	8.5	12	14
GL2 - 8 × 1/2 B1	8	1/2	34	24	31	12	17	14
GL2 - 10 × 1/8 B1	10	1/8	29	20	23	4	14	17
GL2 - 10 × 1/4 B1	10	1/4	29	21	24	6	12	17
GL2 - 10 × 3/8 B1	10	3/8	29	21	25	8.5	12	17
GL2 - 10 × 1/2 B1	10	1/2	34	24	31	12	17	17
GL2 - 12 × 1/4 B1	12	1/4	32	22	25	6	14	19
GL2 - 12 × 3/8 B1	12	3/8	32	22	26	8.5	14	19
GL2 - 12 × 1/2 B1	12	1/2	34	24	31	12	17	19
GL2 - 14 × 3/8 B1	14	3/8	35	25	28	8.5	17	23
GL2 - 14 × 1/2 B1	14	1/2	35	25	31	12	17	23
GL2 - 15 × 3/8 B1	15	3/8	34	25	28	8.5	17	23
GL2 - 15 × 1/2 B1	15	1/2	34	25	31	12	17	23
GL2 - 20 × 1/2 B1	20	1/2	40	29	34	12	23	29
GL2 - 20 × 3/4 B1	20	3/4	40	29	36	17	23	29
GL2 - 25 × 1" B1	25	1"	47	35	46	20	35	36

GL1型 B1 UNION ELBOW

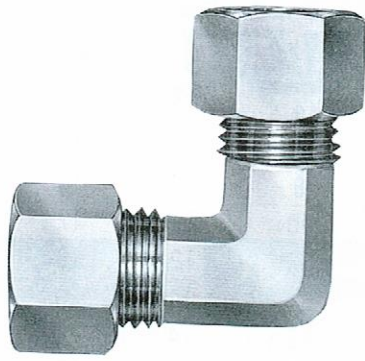

呼称	P	E	h	H	B	A
GL1 - 4 - B1	4	25	8	10	16	25
GL1 - 6 - B1	6	4	8	12	19	27
GL1 - 8 - B1	8	6	10	14	19	27
GL1 - 10 - B1	10	8	12	17	20	29
GL1 - 12 - B1	12	10	14	19	22	32
GL1 - 14 - B1	14	11	17	23	25	34
GL1 - 15 - B1	15	12	17	23	25	34
GL1 - 20 - B1	20	17	23	29	29	39
GL1 - 25 - B1	25	20	29	36	35	45

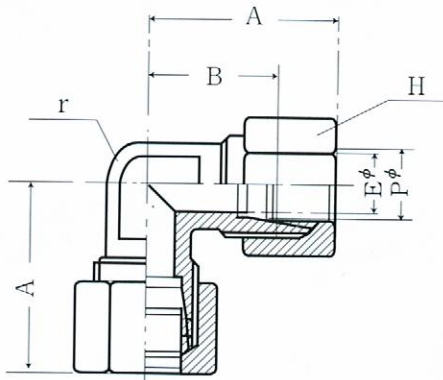

GSPB 1型 FEMAL CONNECTOR FOR PRESSURE GAUGE

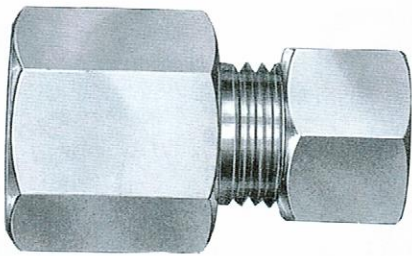

呼称	P	T _(PF)	E	E ₁	h	H	ℓ ₁	ℓ ₂	L
GSP - ¼ × 6 - B1	6	¼	4	6	17	12	29	14	37
GSP - ¼ × 8 - B1	8	¼	6	6	17	14	29	14	37
GSP - ¼ × 10 - B1	10	¼	8	6	17	17	29	14	38
GSP - ⅜ × 6 - B1	6	⅜	4	6	21	12	30	15	38
GSP - ⅜ × 8 - B1	8	⅜	6	6	21	14	30	15	38
GSP - ⅜ × 10 - B1	10	⅜	8	8	21	17	30	15	39
GSP - ½ × 6 - B1	6	½	4	6	26	12	33	16	40
GSP - ½ × 8 - B1	8	½	6	6	26	14	33	16	40
GSP - ½ × 10 - B1	10	½	8	8	26	17	33	16	41

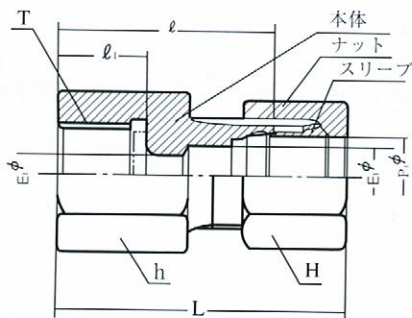

GTTV型 ミニチュアバルブ COMPRESSION LING



呼 称	適用管 外径	L	H	h ₁	B	D
GTTV 6	6	49	38	4	14	25
GTTV 8	8	66	52	4	17	32
GTTV 10	10	67	52	4	19	32
GTTV 12	12	73	54	4	21	32
GTTV 15	15	83	57	4	26	40

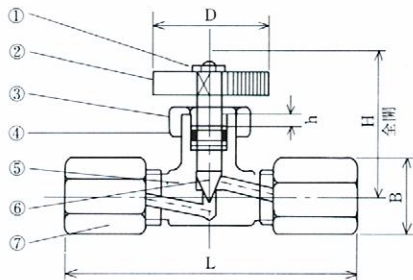

- ①六角ナット C3604
- ②ハンドル C3604
- ③グランドナット C3604
- ④ロリング JISB-2401 1~2
- ⑤バルブ本体 C3771
- ⑥弁棒 JISH-3741 C5101
- ⑦ナット C3771

GTTV-22、28はJR
(旧国鉄)指定商品
に付き弁棒部の組
立構図が違います
ので資料請求の時
は御用命下さい。

GT3V型 ミニチュアバルブ COMPRESSION ANGLE



呼 称	適用管 外径	L	H	h ₁	B	D	(P.T) T
GT3V 6 × 1/8	6	40	34	4	14	25	1/8
GT3V 6 × 1/4	6	42	38	4	14	25	1/4
GT3V 8 × 1/4	8	49	53	4	17	32	1/4
GT3V 10 × 3/8	10	51	53	4	19	32	3/8
GT3V 12 × 3/8	12	55	55	4	21	32	3/8

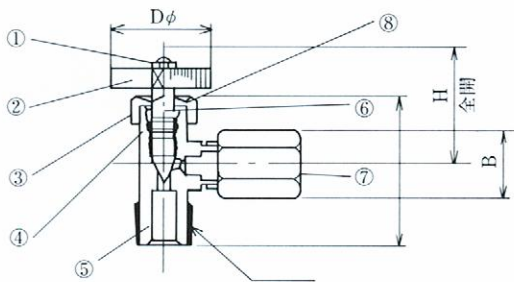

- ①六角ナット C3604
- ②ハンドル C3604
- ③グランドナット C3604
- ④ロリング JISB-2401 1~2
- ⑤バルブ本体 C3771
- ⑥弁棒 JISH-3741 C5101
- ⑦ナット C3771
- ⑧パッキン

GT4V型 ミニチュアバルブ COMPRESSION



呼 称	適用管 外径	L	H	h ₁	B	D	(P.T) T
GT4V 6 × 1/8	6	47	38	4	14	25	1/8
GT4V 6 × 1/4	6	49	38	4	14	25	1/4
GT4V 8 × 1/4	8	57	52	4	17	32	1/4
GT4V 10 × 3/8	10	62	52	4	19	32	3/8
GT4V 12 × 3/8	12	64	54	4	21	32	3/8

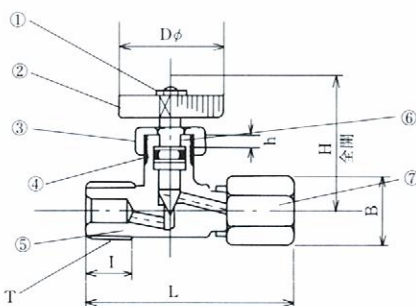

- ①六角ナット C3604
- ②ハンドル C3604
- ③グランドナット C3604
- ④ロリング JISB-2401 1~2
- ⑤バルブ本体 C3771
- ⑥弁棒 JISH-3741 C5101
- ⑦ナット C3771

GU1型 B1 UNION

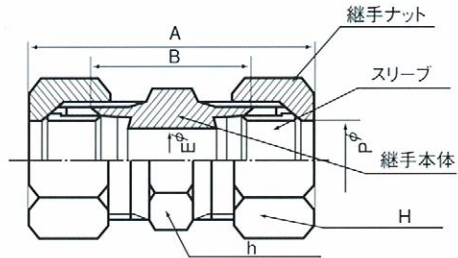
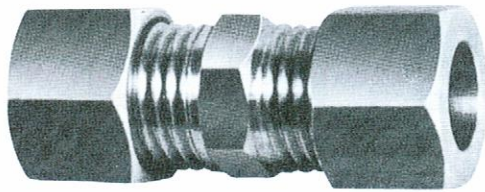

呼称	P	A	B	E	h	H
GU1-4-B1	4	35	20	2.5	8	10
GU1-6-B1	6	38	22	4	10	12
GU1-8-B1	8	39	23	6	12	14
GU1-10-B1	10	42	25	8	14	17
GU1-12-B1	12	46	26	10	17	19
GU1-14-B1	14	46	27	11	21	23
GU1-15-B1	15	46	27	12	21	23
GU1-20-B1	20	50	30	17	26	29
GU1-25-B1	25	54	34	20	20	36

GC型 B1 MALE CONNECTOR

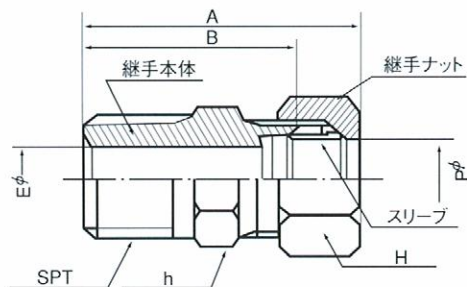
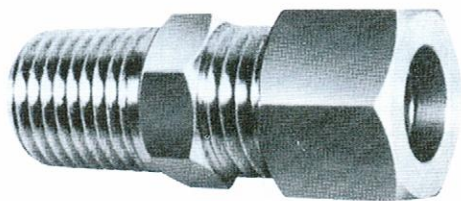

呼称	P	S	A	B	E	h	H
GC-4 × 1/8 B1	4	1/8	31	23	2.5	10	10
GC-6 × 1/8 B1	6	1/8	32	24	4	10	12
GC-6 × 1/4 B1	6	1/4	37	29	4	14	12
GC-6 × 3/8 B1	6	3/8	38	30	4	17	12
GC-6 × 1/2 B1	6	1/2	44.5	37	4	23	12
GC-8 × 1/8 B1	8	1/8	33	25	4	12	14
GC-8 × 1/4 B1	8	1/4	37	29	6	14	14
GC-8 × 3/8 B1	8	3/8	38	30	6	17	14
GC-8 × 1/2 B1	8	1/2	45	37	6	23	14
GC-10 × 1/8 B1	10	1/8	35	26	4	14	17
GC-10 × 1/4 B1	10	1/4	38	30	6	14	17
GC-10 × 3/8 B1	10	3/8	39	31	8	17	17
GC-10 × 1/2 B1	10	1/2	46	37	8	23	17
GC-12 × 1/4 B1	12	1/4	39	31	6	17	19
GC-12 × 3/8 B1	12	3/8	40	32	8.5	17	19
GC-12 × 1/2 B1	12	1/2	46	37	10	23	19
GC-14 × 3/8 B1	14	3/8	43	33	8.5	21	23
GC-14 × 1/2 B1	14	1/2	47	37	11	23	23
GC-15 × 3/8 B1	15	3/8	43	33	8.5	21	23
GC-15 × 1/2 B1	15	1/2	47	37	12	23	23
GC-20 × 1/2 B1	20	1/2	48	39	12	26	29
GC-20 × 3/4 B1	20	3/4	51	42	17	29	29
GC-25 × 3/4 B1	25	3/4	53	43	17	32	36
GC-25 × 1" B1	25	1"	56	46	20	35	36

GL1型 B1 UNION ELBOW

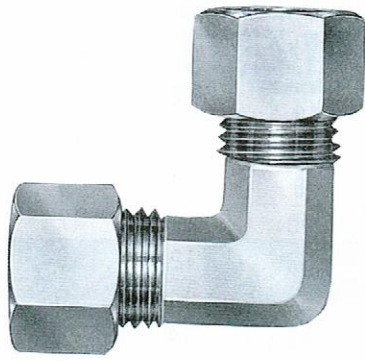

呼称	P	E	h	H	B	A
GL1 - 4 - B1	4	25	8	10	16	25
GL1 - 6 - B1	6	4	8	12	19	27
GL1 - 8 - B1	8	6	10	14	19	27
GL1 - 10 - B1	10	8	12	17	20	29
GL1 - 12 - B1	12	10	14	19	22	32
GL1 - 14 - B1	14	11	17	23	25	34
GL1 - 15 - B1	15	12	17	23	25	34
GL1 - 20 - B1	20	17	23	29	29	39
GL1 - 25 - B1	25	20	29	36	35	45

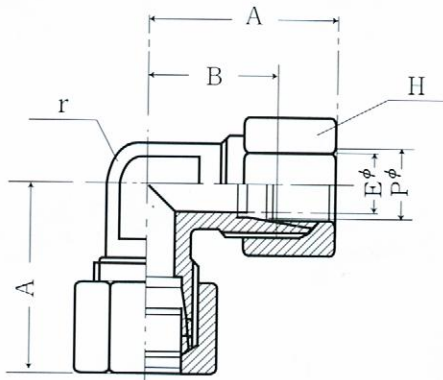

GSPB 1型 FEMAL CONNECTOR FOR PRESSURE GAUGE

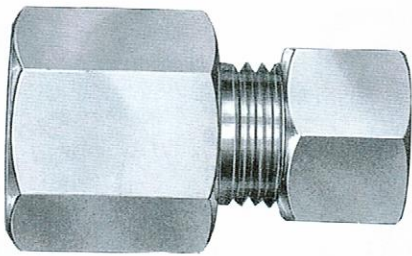

呼称	P	T _(PF)	E	E ₁	h	H	ℓ ₁	ℓ ₂	L
GSP - ¼ × 6 - B1	6	¼	4	6	17	12	29	14	37
GSP - ¼ × 8 - B1	8	¼	6	6	17	14	29	14	37
GSP - ¼ × 10 - B1	10	¼	8	6	17	17	29	14	38
GSP - ⅜ × 6 - B1	6	⅜	4	6	21	12	30	15	38
GSP - ⅜ × 8 - B1	8	⅜	6	6	21	14	30	15	38
GSP - ⅜ × 10 - B1	10	⅜	8	8	21	17	30	15	39
GSP - ½ × 6 - B1	6	½	4	6	26	12	33	16	40
GSP - ½ × 8 - B1	8	½	6	6	26	14	33	16	40
GSP - ½ × 10 - B1	10	½	8	8	26	17	33	16	41

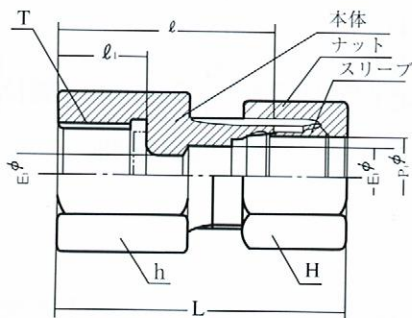

GNB1型 NUT



ナットの呼称	各部の記号	適用する管の外径	L	六角対辺 H	T
GN - 4 - B1		4	10	10	M 8 × P1.0
GN - 6 - B1		6	11	12	M10 × P1.25
GN - 8 - B1		8	12	14	M12 × P1.5
GN - 10 - B1		10	12	17	M14 × P1.5
GN - 12 - B1		12	12.5	19	M16 × P1.5
GN - 14 - B1		14	14	23	M20 × P1.5
GN - 15 - B1		15	14	23	M20 × P1.5
GN - 20 - B1		20	14.5	29	M26 × P1.5
GN - 25 - B1		25	14.5	36	M32 × P1.5

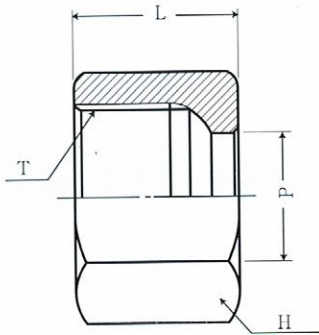

GOB1型 SLEEVE



継手の呼称	適用する管外径 P	ℓ
GO - 4 - B1	4	7
GO - 6 - B1	6	7
GO - 8 - B1	8	7.5
GO - 10 - B1	10	7.5
GO - 12 - B1	12	7.5
GO - 14 - B1	14	8.5
GO - 15 - B1	15	8.5
GO - 20 - B1	20	8.5
GO - 25 - B1	25	9

